



Enriching Lives

PROCESS PUMPS

TYPE - KPD / KPD-QF / KPDT / KPDJ



KIRLOSKAR BROTHERS LIMITED

A Kirloskar Group Company



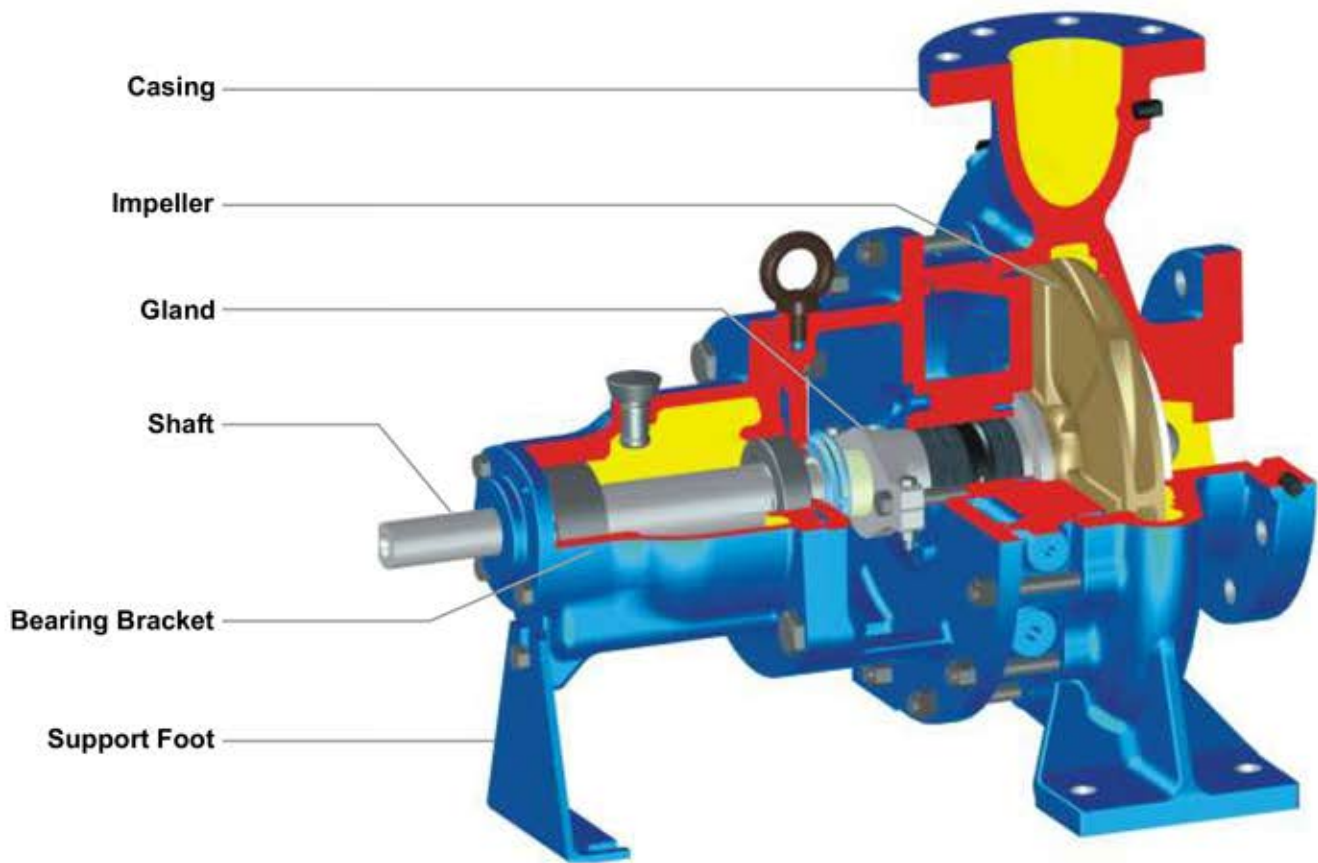

RANGE

Delivery size : up to 200 mm
 Capacity : up to 900 m³/hr
 Head : up to 225 metres
 Working : 16-30 kg/cm²
 Pressures
 Temperature : (-)50°C to + 350°C

APPLICATIONS

Chemical Process Industries, Petro Chemical, Nuclear, Refinery, Paper, Power Plants and Sugar Plants etc.
 Pumps suitable for handling Corrosive Liquids, Alkalies, Salt Solutions, Caustics, Hydro Carbons, Oils, Thermic Fluids, Liquefied Gases, Condensates, Viscous Liquids and Congealing Liquid etc.

FEATURES

Pumps are as per EN 22858 (DIN 24256) and ISO 2858. The design is of back pull out type. Large variety of models are available to operate at 1450 rpm and 2900 rpm at 50Hz/60Hz.

Casing :

The casing has axial suction and top centre line delivery. Smooth hydraulic passages ensure high efficiency. Normal design is for foot mounted pumps. Centre line mounting for special applications are also available. Jacketed Casings are available for handling congealing liquid.

Impeller :

The impellers are of enclosed type and semi-open impellers can also be supplied. Hydraulic balancing of impellers is achieved either by back vanes or by balancing holes. The impellers are statically and dynamically balanced. Reliable fixing of the impeller on shaft is achieved by using helicoil insert under impeller nut. To improve NPSH performance, inducer can be supplied.

Shaft :

The shaft is supported by two antifriction bearings to take residual axial thrust and prevent axial float or radial run out. It is fully protected from the liquid handled by means of a shaft sleeve and gaskets between impeller nut, impeller hub and shaft sleeve.

Stuffing Box :

The stuffing box is sealed by gland packing or by cartridge type mechanical seal. Conversion from gland packing to mechanical seal is achieved by changing some standardised parts. Re-machining of stuffing box is not necessary. Stuffing box cooling is provided for operating temperature 105°C for gland packed and 140°C for mechanical seal fitted pumps.

Bearing :

The bearings are oil lubricated. For high temperature (above 180°C) application, bearing oil cooling arrangement is provided. All pumps are provided with reinforced bearing arrangement as standard supply.

Direction of Rotation :

Clockwise viewed from driving end.

Drive :

Pumps can be driven by electric motor or engine.

Flanges :

ANSI B 16.1, CL 125 Flat Face : for CI/BR

ANSI B 16.5, CL 150 Raised Face - for sp.metals viz. st.steel, cast steel etc.

Drilling as per DIN, ASA, BS etc. (Optional)

GENERAL DIMENSIONS / MOUNTING DETAILS

Centreline Mounted CLM Pump (KPD/KPD-QF/KPDT)

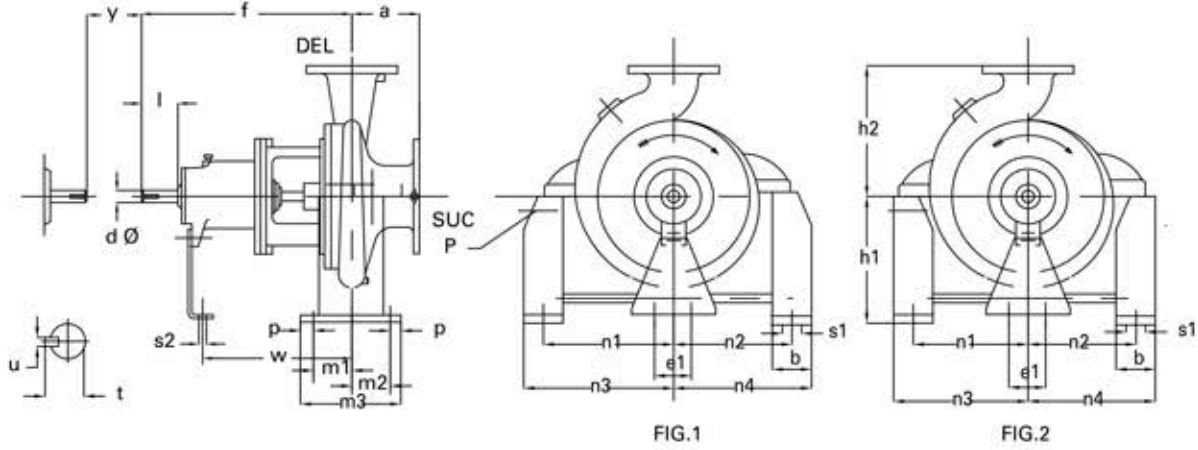

PUMP TYPE	DRV. UNIT	PUMP DIMENSIONS											FOOT DIMENSIONS								SHAFT END					SPR.	FIG. NO.																		
		DEL	SUC	a	f	h1	h2	b	c	m1	m2	m3	n1	n2	n3	n4	w	s1	s2	e1	p	d∅	l	t	u			y																	
20/13 QF	4	20	25	80	385	200	64	72	88	190	15	125	125	157	157	285	14	14	23	18	40	20.5	6	100	1																				
20/16 QF												130	130	162	162										1																				
20/20 QF												155	155	187	187										1																				
25/16 QF												170	145	177	177										1																				
32/13	5	32	50	80	385	200	64	72	88	190	15	125	125	157	157	285	14	14	23	18	40	20.5	6	100	2																				
32/16												155	145	187	177										1																				
32/20												170	165	202	197										2																				
40/13												135	125	167	157										2																				
40/16												160	165	197	197										1																				
40/20	170	165	202	197	2																																								
50/13	5	40	65	80	385	200	64	72	88	190	15	170	165	202	197	285	14	14	23	18	40	20.5	6	100	1																				
50/16												180	165	202	197										2																				
50/20												180	165	202	197										2																				
65/13												180	165	202	197										1																				
25/26A												25	50	100	225										250	90	89.5	110.5	230	260	240	305	285	370	18	140	15	110	32	80	35	10	140	1	
32/26												32	50	100	225										250	90	89.5	110.5	230	260	240	305	285	370	18	140	15	110	32	80	35	10	140	1	
40/26	40	65	100	250	280	90	89.5	110.5	230	260	230	305	275	370	18	140	15	110	32	80	35	10	140	1																					
40/32	40	65	125	250	280	90	89.5	110.5	230	260	230	305	275	370	18	140	15	110	32	80	35	10	140	2																					
50/26	7	50	80	125	500	250	90	72	88	190	15	220	220	252	252	370	18	14	15	110	32	80	35	10	140	1																			
50/32												220	220	252	252											2																			
65/16												65	100	100	200											280	64	72	88	190	210	175	242	207	370	18	140	15	110	32	80	35	10	140	1
65/20												65	100	100	225											280	64	72	88	190	210	175	242	207	370	18	140	15	110	32	80	35	10	140	2
65/26												65	100	100	250											280	90	89.5	110.5	230	260	230	305	275	370	18	140	15	110	32	80	35	10	140	1
80/16												80	125	100	225											280	64	72	88	190	210	175	242	207	370	18	140	15	110	32	80	35	10	140	1
80/20												80	125	100	250											280	64	72	88	190	210	175	242	207	370	18	140	15	110	32	80	35	10	140	2
80/26												80	125	100	280											280	90	89.5	110.5	230	260	230	305	275	370	18	140	15	110	32	80	35	10	140	1
100/20												100	125	100	250											280	90	89.5	110.5	230	260	230	305	275	370	18	140	15	110	32	80	35	10	140	1
65/32												65	100	100	280											280	90	92.5	107.5	230	260	230	305	275	370	18	140	15	110	32	80	35	10	140	2
80/32	9	80	125	150	530	365	90	18	100	150	300	18	100	150	300	310	295	355	340	23	25	15	42	110	45	12	180	1																	
80/40												15	92.5	107.5	230	260	230	305	275	23	25	15	42	110	45	12	180	2																	
100/26												15	92.5	107.5	230	260	230	305	275	23	25	15	42	110	45	12	180	2																	
100/32												15	92.5	107.5	230	260	230	305	275	23	25	15	42	110	45	12	180	1																	
100/40												15	92.5	107.5	230	260	230	305	275	23	25	15	42	110	45	12	180	2																	
125/26												15	92.5	107.5	230	260	230	305	275	23	25	15	42	110	45	12	180	1																	
125/32												15	92.5	107.5	230	260	230	305	275	23	25	15	42	110	45	12	180	2																	
125/40												15	92.5	107.5	230	260	230	305	275	23	25	15	42	110	45	12	180	2																	
150/32												15	92.5	107.5	230	260	230	305	275	23	25	15	42	110	45	12	180	1																	
150/40												15	92.5	107.5	230	260	230	305	275	23	25	15	42	110	45	12	180	1																	
125/26	11	125	150	140	315	355	100	22	120	160	340	310	295	355	340	500	19	140	30	48	110	51.5	14	180	1																				
200/38M	13	200	250	200	670	400	500	100	22	120	160	340	410	360	465	415	483.5	27	19	140	30	60	110	64.4	18	180	2																		
200/46													425	550	465	415											2																		
150/52													150	200	200	400											550	440	395	495	450	2													

GENERAL DIMENSIONS / MOUNTING DETAILS

Foot Mounted (FM) Pump (KPD/KPD-QF)

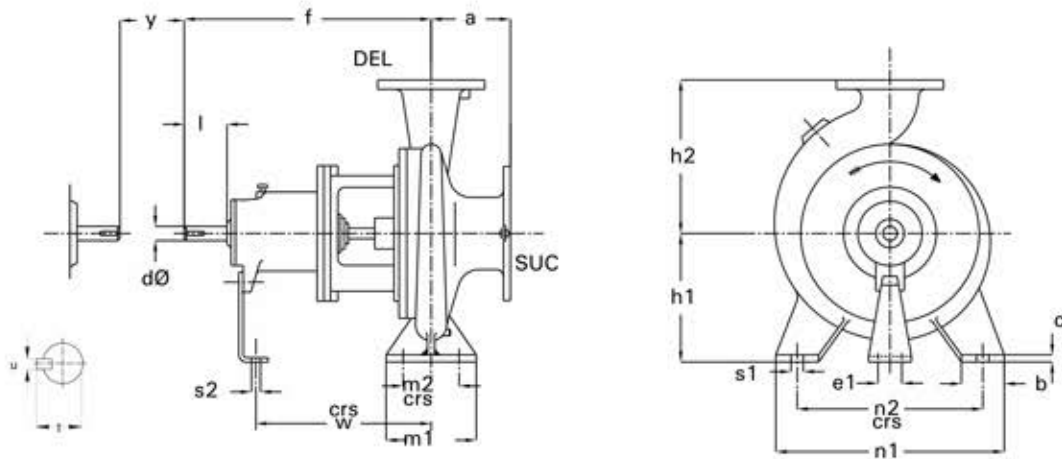

Pump Type	Drg. Unit	Pump Dimensions						Foot Dimensions								Shaft End					Wt. Kg.						
		SUC	DEL	a	f	h1	h2	b	c	m1	m2	n1	n2	w	s1	s2	e1	dØ	l	t		u	y				
20/13QF #	4	25	20	80	385	100	140	50	10	80	50	190	140	285	14	14	110	18	40	20.5	6	100	1				
20/16QF #						132	150					210	160										38				
20/20QF #						160	170					240	190										43				
25/16QF #	5	40	25	100	385	132	165	50	14	100	70	210	160	285	14	15	110	24	50	27	8	100	36				
25/20QF #						180	10					80	50										265	212	44		
32/13						112	140					190	140										38				
32/16		50	32	80	385	132	160	50	14	100	70	210	160	285	14	15	110	24	50	27	8	100	40				
32/20																							160	180	240	190	47
40/13																							112	140	210	160	39
40/16		65	40	100	385	132	160	50	14	100	70	240	190	285	14	15	110	24	50	27	8	100	42				
40/20																							160	180	265	212	48
50/13																							132	160	240	190	42
50/16		80	50	100	385	160	180	50	14	100	70	265	212	285	14	15	110	24	50	27	8	100	46				
50/20																							200	265	212	53	
65/13																							160	180	280	212	69
25/26	7	50	25	100	500	180	225	65	125	95	320	250	370	14	15	110	32	80	35	10	140	90					
32/26																						180	225	320	250	90	
40/26																						65	40	125	320	90	
40/32		80	50	125	500	200	250	65	14	125	95	345	280	370	14	15	110	32	80	35	10	140	103				
50/26																							180	225	320	250	90
50/32																							225	280	345	280	120
65/16		100	65	100	500	160	200	180	225	125	95	280	212	370	15	110	110	32	80	35	10	140	77				
65/20																							180	225	320	250	79
65/26																							200	250	360	280	96
80/16		125	80	125	500	180	225	65	14	125	95	320	250	370	14	15	110	32	80	35	10	140	85				
80/20																							250	345	280	86	
80/26																							225	280	400	315	116
100/20	125	100	125	500	200	280	80	16	160	120	360	280	370	18	15	110	32	80	35	10	140	106					
65/32	9	100	65	125	530	225	280	80	16	160	120	400	315	370	18	110	42	110	45	12	140	140					
80/32																						250	315	400	315	146	
80/40																						280	355	435	355	181	
100/26		125	80	140	530	225	280	100	18	160	120	400	315	370	23	15	110	42	110	45	12	140	134				
100/32																							250	315	400	315	157
100/40																							280	355	435	355	164
125/26		150	125	140	530	250	355	80	16	160	120	400	315	370	18	15	110	42	110	45	12	140	158				
125/32																							280	355	370	315	179
125/40																							315	400	400	315	212
150/32		200	150	160	530	315	400	100	22	200	150	500	400	370	23	15	110	42	110	45	12	140	260				
150/40 \$																							315	450	550	450	285

All dimensions are in mm

GENERAL DIMENSIONS / MOUNTING DETAILS

Foot Mounted (KPD/KPDQF) Pump

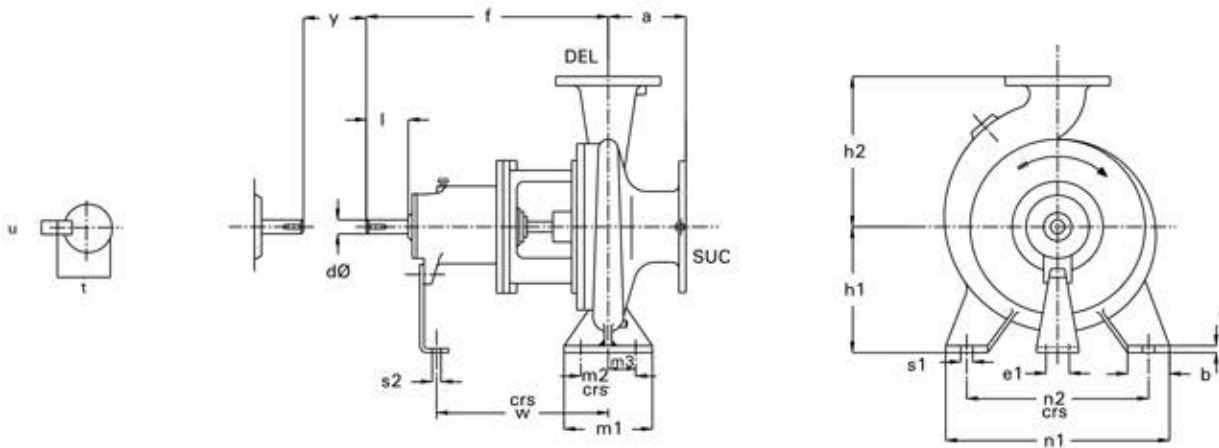

Pump Size	Driving Unit	Pump Dimensions						Foot Dimensions										Shaft End				Wt. Kg.		
		SUC	Del	a	f	h1	h2	b	c	m1	m2	m3	n1	n2	w	s1	s2	e1	d*	l	t		u	y
125/45 \$	11A	150	125	160	670	350	450	100	20	180	120	70	550	450	500	23	19	140	48	110	51.4	14	180	290
150/43 \$	11B	200	150	160	685	350	475	100	20	180	120	90	550	450	514	23	19	140	48	110	51.4	14	180	300
65/43 \$	9	100	65	160	530	280	365	80	18	160	120	60	435	355	370	18	15	110	42	110	45	12	140	195

Pump Size	Driving Unit	Pump Dimensions						Foot Dimensions										Shaft End				Wt. Kg.	
		DEL	SUC	a	f	h1	h2	b	c	m1	m2	n1	n2	w	s1	s2	e1	dØ	l	t	u		y
100/16	7	100	125	150	500	225	280	65	14	125	95	320	250	370	14	15	110	32	80	35	10	140	97
125/20	9	125	125	140	530	250	315	80	16	160	120	400	315	370	18	15	110	42	110	45	12	140	138
125/26	11	125	150	140	670	280	355	80	16	160	120	400	315	500	18	19	140	48	110	51.5	14	140	190
150/26	9	150	200	160	530	280	375	100	20	200	150	500	400	370	23	15	110	42	110	45	12	140	175
150/52 \$		150	200	200	670	400	550	150	30	240	180	650	530	483	27	19	140	60	110	64.4	18	180	435
200/38M \$	13	200	250	200	670	400	500	120	30	240	180	550	430	483.5	27	19	140	60	110	64.4	18	180	550
200/46 \$		200	250	200	670	425	550	120	30	240	180	640	540	483.5	27	19	140	60	110	64.4	18	180	560
80/40DV	11	80	125	125	670	280	355	80	16	160	120	435	355	500	18	19	140	48	110	51.5	14	180	177
100/40DV	11	100	150	140	670	280	355	100	18	200	150	500	400	500	23	19	140	48	110	51.5	14	180	200

Note :

- # These pumps provided with semi open impeller only.
- § These pumps cannot be supplied with semi open impeller.

All dimensions are in mm

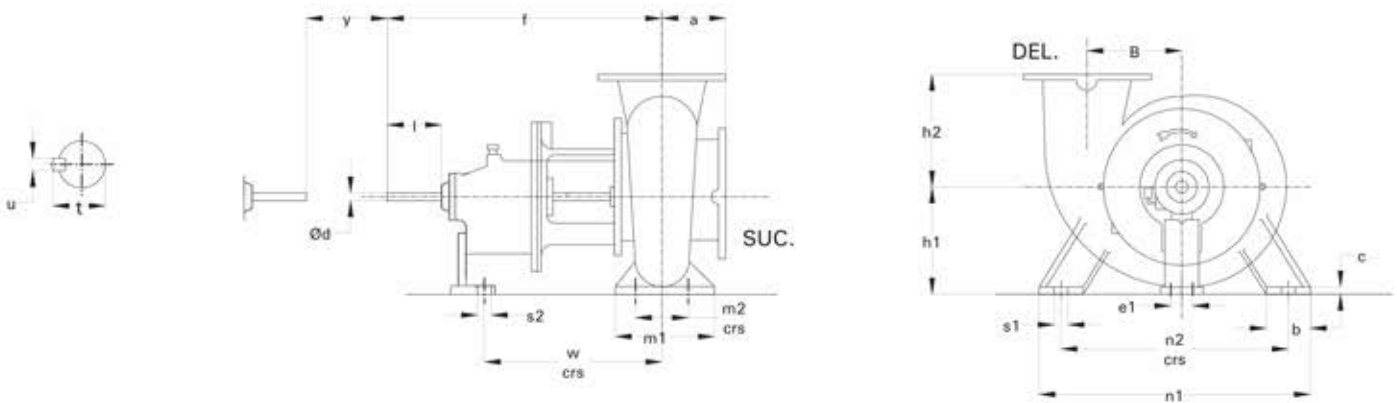

Pump Size	Driving Unit	Pump Dimensions						Foot Dimensions										Shaft End				Wt. Kg.		
		SUC	Del	a	F	H1	h2	B	b	c	m1	m2	n1	n2	w	s1	s2	e1	Ød4	l	t		u	y
200 / 33	11C	200	200	200	720	370	315	265	100	25	335	265	630	560	650	27	19	140	48	110	51.4	14	180	280

CROSS SECTIONAL VIEW

KPD (Foot Mounted)

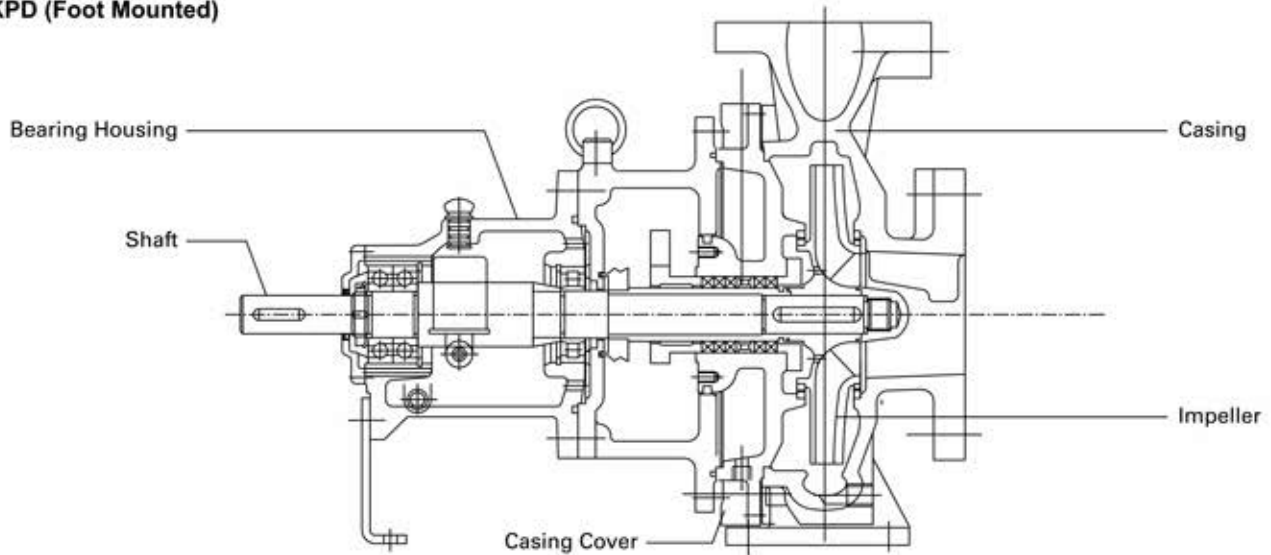

INTERCHANGEABILITY OF COMPONENTS

Pump Unit	Size	Casing	Impeller	Casing Cover	Bearing Housing & Shaft
5	32/13	1	1	1	1
	40/13	2	2		
	50/13	3	3		
	65/13	4	4		
	32/16	5	5	2	
	32/16A	6	6	3	
	40/16	7	7	2	
	50/16	8	8	2	
	50/16A	9	9	3	
	32/20	10	10	4	
	32/20A	11	11	5	
	40/20	12	12	4	
	40/20A	13	13	5	
50/20	14	14	4		
7	65/16	14	15	6	2
	80/16	15	16	7	
	65/20	16	17		
	80/20	17	18		
	100/20	18	19		
	25/26	19	20	8	
	32/26	20	21	9	
	40/26	21	22		
	50/26	22	23		
	65/26	23	24		
	65/26N	24	25		
	80/26	25	26		
	40/32	26	27		
50/32	27	28	10		
100/16	28	29	11		
100/26	29	30	12		
125/26	30	31	13		
9	65/32 (1450 rpm)	30	32	3	
	65/32 (2900 rpm)	31	33		
	80/32	32	34		
	100/32	33	35		
	125/32	34	36		
	150/32	35	37		
	150/32N	36	38		
	80/40	37	39		
	80/40N	38	40		
	100/40	39	41		
	125/40	40	42		
	125/40N	41	43		
	125/20	42	44		
150/26	43	45			
150/40	44	46			
65/43	45	47			
80/40DV	46	48			
11	125/26 (2900 rpm)	47	49	17	4
11	100/40DV	48	50	18	
11/A	125/45	49	51	19	
11/B	150/43	50	52	20	
11/C	200/33	51	53	21	5
13	150/52	52	54	22	
	200/38M	53	55	23	
13	200/46	54	56	24	6
	200/46	55	57	25	
13	200/46	56	58	26	7
	200/46	57	59	27	
13	200/46	58	60	28	8
	200/46	59	61	29	

CROSS SECTIONAL DRAWING

KPD-QF (Foot Mounted)

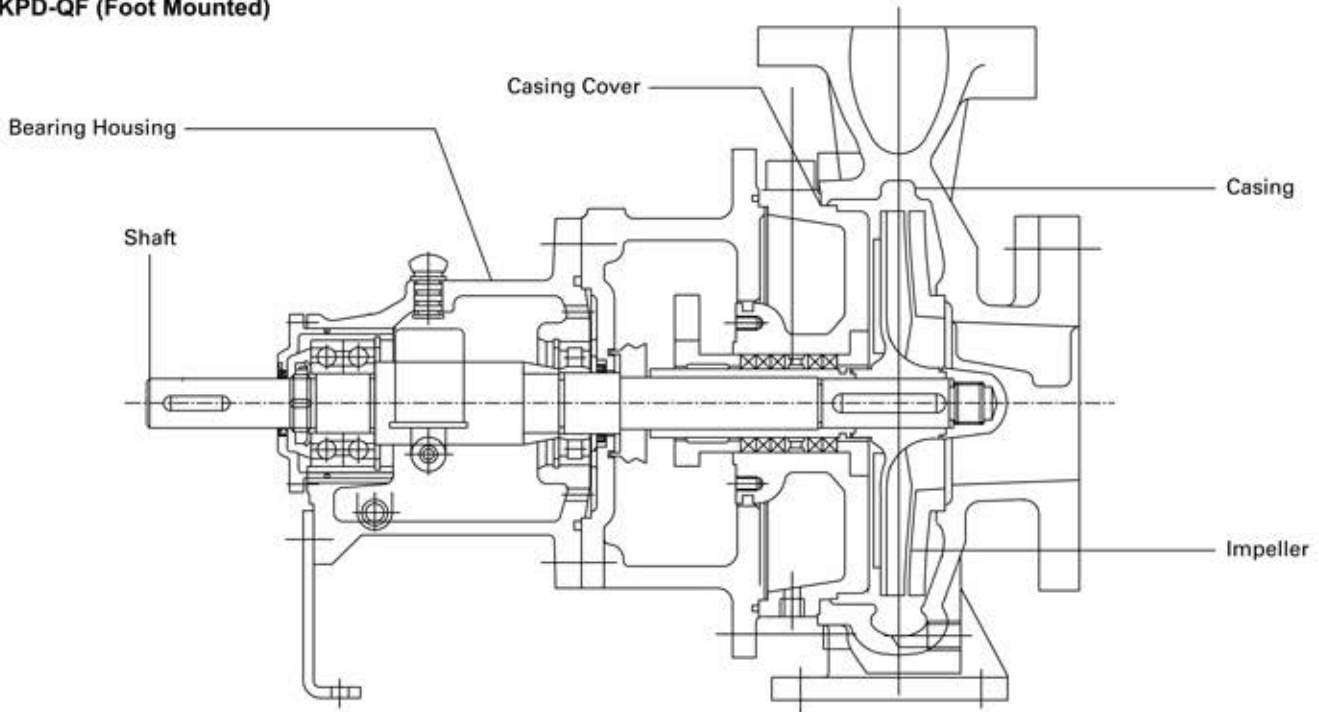

INTERCHANGEABILITY OF COMPONENTS

Pump Unit	Size	Casing	Impeller	Casing Cover	Bearing Housing & Shaft
4	20/13	1	1	1	1
	20/16	2	2	2	
	20/20	3	3	3	
5	32/13	4	4	4	2
	40/13	5	5		
	50/13	6	6		
	65/13	7	7		
	25/16	8	8	5	
	32/16	9	9	6	
	40/16	10	10	7	
	50/16	11	11	8	
	32/20	12	12		
	40/20	13	13		
	50/20	14	14	9	
7	65/16	15	15	10	3
	80/16	16	16	11	
	65/20	17	17		
	80/20	18	18		
	100/20	19	19	12	
	32/26	20	20	13	
	40/26	21	21	14	
	50/26	22	22		
	65/26	23	23		
	80/26	24	24		
	40/32	25	25	16	
50/32	26	26	17		
100/26	27	27			
125/26	28	28			
9	65/32	29	29	18	4
	80/32	30	30		
	100/32	31	31		
	125/32	32	32	19	
	150/32	33	33		
	80/40	34	34		
	100/40	35	35		
	100/40	35	35		
	125/40	36	36		

FEATURES (KPDT)

Applications

KPD-T pumps are designed for handling Thermic fluids, Synthetic Oil, Hot Oil etc. The working temperature range is normally 200°C and above.

Constructional Features

Pump with centerline mounted delivery casing

Pump with stuffing box cooling and bearing cooling arrangement

Pump in all Cast Steel construction i.e. MOC code 10. (All CF8M MOC very rarely offered.)

Pump with Grafoil packing rings for gland packed execution

Pump in solid gland in cast steel material. Instead of spilt gland.

Pump with special close clearance stuffing box bush

Gaskets:

- Spiral wound gasket in between casing and casing cover

- Other gaskets coming in liquid contact are in Grafoil

Mechanical seals are metal bellow type as per seal manufacturer's recommendations

Stuffing box jacket is formed using vition 'O'ring or welding sheet metal to casing cover depending upon considering temperature of fluid

Metallic oil breather

Flange Drilling

Flange drilling will be as per ANSI B16.5 CL 150 RF or ANSI B16.5 CL 300 RF. Drilling standard will depend on the temperature of fluid and working pressure.

Care Taken For Accessories Selection

Due to high temperature applications pumps to be offered with suitable API cooling plans or cooling plan provisions. Plan G and H are popular.

Pumps are offered with flexible metallic coupling. Use of rubber spider is avoided.

Unique Feature

Pump can be offered with CE marking

Depending upon the application, area classification ATEX marking can be done

- Heat barrier is created by way of cooling the stuffing box region & sufficient space is kept between stuffing box and bearing, so that heat is not conducted to bearings

- Special heat resistant painting

CROSS SECTIONAL DRAWING (KPDT)

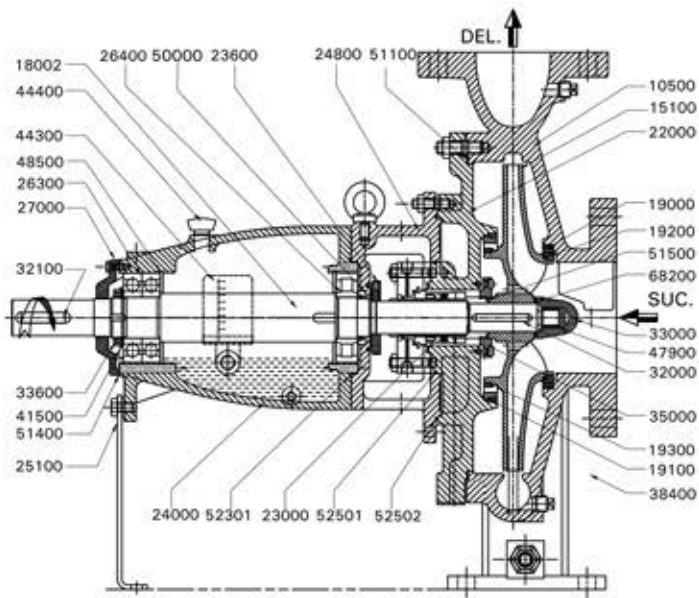

SECTION A-A

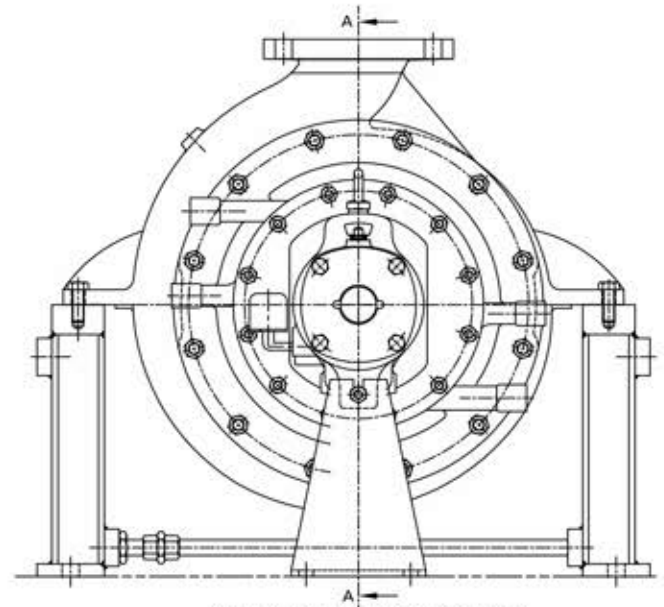

VIEW FROM DRIVING END

PART NO.	QTY	PART DESCRIPTION	PART NO.	QTY	PART DESCRIPTION
10500	01	Pump Casing	32100	01	Key For Coupling
15100	01	Enclosed Impeller	33000	01	Impeller Nut
18002	01	Pump Shaft	33600	01	Impeller Lock Nut
19000	01	Casing Ring Suc.	35000	01	Stuffing Box Bush
19100	01	Casing Ring Del.	38400	01	Pad For Clm Pump
19200	01	Impeller Ring Suc.	41500	01	Lock Washer For Bearing Lock Nut
19300	01	Impeller Ring Del.	43000	01	Gland Packing
22000	01	Casing Cover	44300	01	Constant Level Oiler
22900	01	Split Gland	44400	01	Oil Feeding Plug
23600	01	Liquid Deflector	47900	01	Helicoil Insert
24000	01	Bearing Housing	48500	01	Internal Circlip
24800	01	Lantern Bracket	50001	01	Oil Seal Ds
25100	01	Support Foot	51100	01	Gasket for Csg & Csg Cover
26300	01	Angular Contact Bearing De	51400	01	Gasket for De Bearing Cover
26400	01	Cylindrical Roller Bearing Nde	51500	01	Gasket for Sleeve & Imp
27000	01	Bearing Cover (de)	52300	01	O-ring
31100	01	Shaft Sleeve	52501	01	O-ring for C.cover & Lant. Bracket
32000	01	Key For Impeller	52502	01	O-ring for Lan. Bkt. & Csg.cover
			68200	01	Gasket Betw. Impeller Nut & Impeller Lock Nut

BACK PULL OUT ARRANGEMENT

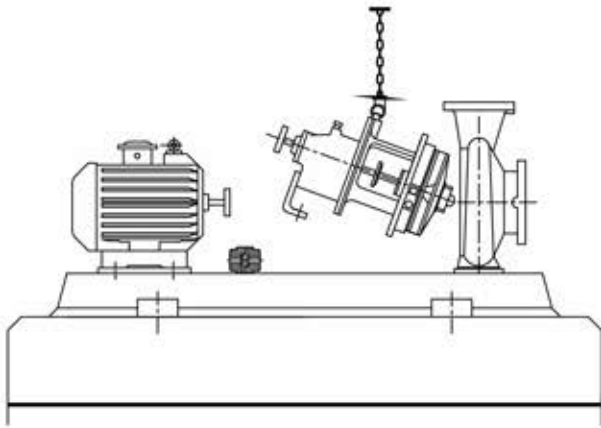

Using spacer type coupling, back-pullout design enables the pump rotating unit to be removed without disturbing the pipe connections. The prime mover is also undisturbed. This reduces servicing time, resulting in lower maintenance costs and reduction in production losses.

ALTERNATIVES AVAILABLE

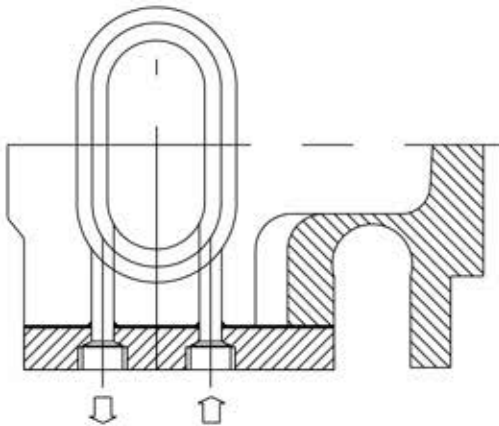

Bearing Oil Cooling Arrangement

For high temperature applications above 180°C bearing oil cooling arrangement is provided.

Steam Jacket Arrangement

This special design can be offered for handling liquids that cannot be pumped when cold. Except for pump casing, casing cover and gland, all parts are of standard design.

Steam Jacket Arrangement

WORKING TEMPERATURE AND PRESSURE

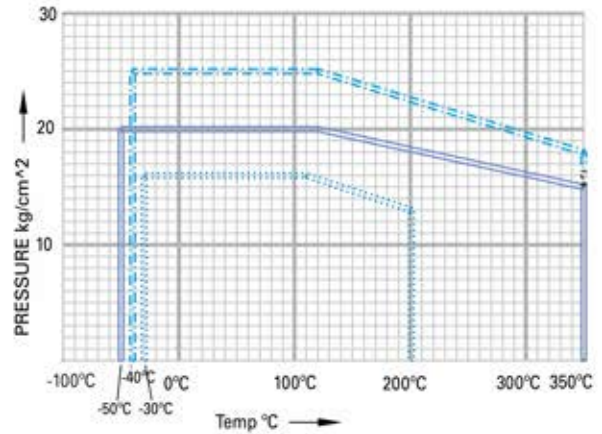

Note :

The pressure and temperature data holds good only if flanges are suitable to a particular operating pressure and temperature.

	CAST ST & ST. STEEL
	S.G. IRON
	C.I. & BRONZE

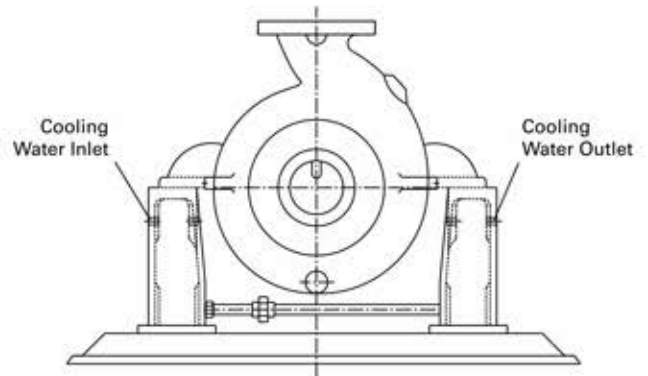

Centre line Mounting

For high temperature applications between 180°C and 350°C, pumps are offered with centreline mounting.

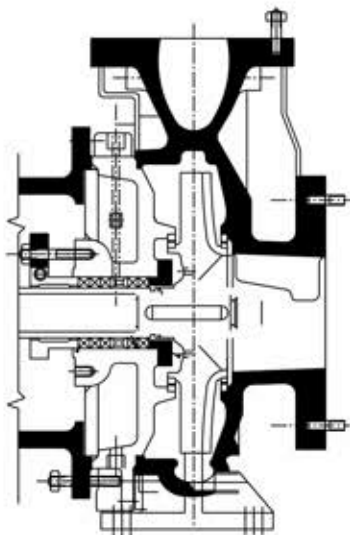

MATERIAL OF CONSTRUCTION

Casing / Casing Cover	Cast Iron / Cast Steel / Stainless Steel / Duplex Steel
Impeller	Cast Iron / Bronze / Cast Steel / Stainless Steel / Chrome Steel / Duplex Steel
Wear Ring / Wear Plate	Cast Iron / Bronze / Steel
Shaft	Carbon Steel / Stainless Steel / Duplex Steel
Shaft Sleeve	Stainless Steel / Bronze

* Bronze material will be suitable for temperature upto 105°C

** Material of construction shall be on the basis of application & liquid characteristics

MATERIAL STANDARDS - GENERAL INFORMATION

Material Type	Indian Standard (IS)	American Standard (ASTM)	DIN
Cast Iron			
Cast Iron	IS 210 Gr. FG 260	ASTM A48 Class 40	(0.6025)DIN 1691 GG25
Spheroidal Graphite Cast Iron			
SG Iron (Ductile Iron)	IS 1865 Gr 400/15	A536, 60-40-18	(0.7040)DIN1693 GGG40
SG Iron (Ductile Iron)	IS 1865 Gr 500/7	A536, 65-45-12	(0.7050)DIN1693 GGG50
Carbon Steel			
Carbon steel (Wrought)	IS 1570 (part II) Gr. 40C8	ASTM A107 Gr. 1040	(1.1186)C40E/CK40
Carbon steel (Wrought)	IS 1570 (part II) Gr. 20C8	ASTM A107 Gr. 1020	(1.0402)C22
MS Steel	MS IS 2062 - Fe 410 W A	ASTM-A283 GR.D FABRICATED STEEL44	DIN 1700 GR ST4-2
Cast Steel Grades			
Cast Steel		ASTMA 216 Gr. WCB	1.0619(GS-C25)
Cast Stainless Steel			
Stainless Steel CF8M	IS 3444 Gr. 4	ASTMA 351 Gr. CF8M	1.4408(GX5CrNiMo19-11-2)
Stainless Steel CF8M	IS 3444 Gr. 4	ASTMA 743 Gr. CF8M	1.4408(GX5CrNiMo19-11-2)
Stainless Steel CF3M	IS 3444 Gr. 16	ASTMA 351 Gr. CF3M	1.4409(GX2CrNiMo19-11-2)
Stainless Steel CF3M	IS 3444 Gr. 16	ASTMA 743 Gr. CF3M	1.4409(GX2CrNiMo19-11-2)
Stainless Steel CF8	IS 3444 Gr. 1	ASTMA 351 Gr. CF8	1.4301(X5CrNi18-10)
Stainless Steel CF3	IS 3444 Gr. 15	ASTMA 351 Gr. CF3	1.4306(X2CrNi19 11)
Cast Chromium Stainless Steel			
Stainless Steel CA15	IS 3444 Gr. 10	ASTMA 217 Gr. CA15	1.4106&1.448(DIN17445 GX12Cr14)
Stainless Steel CA15	IS 3444 Gr. 10	ASTMA 743 Gr. CA15	1.4106&1.448(DIN17445 GX12Cr14)
Stainless Steel CA6NM	IS 3444 Gr. 24	ASTMA 487 Gr. CA6NM	1.4313&1.4317(GX5CrNiMo13-4)
Stainless Steel CA6NM	IS 3444 Gr. 24	ASTMA 743 Gr. CA6NM	1.4313&1.4317(GX5CrNiMo13-4)
Chromium Stainless Steel Round Bar Material			
Stainless Steel 410	IS 1570 (part V) Gr. X12Cr12	ASTMA 276 type 410	1.4006(X10Cr13)
Stainless Steel 420	IS 1570 (part V) Gr. X20Cr13	ASTMA 276 type 420	1.4021(X20Cr13)
Stainless Steel 431	IS 1570 (part V) Gr. X15Cr16Ni2	ASTMA 276 type 431	1.4057(X20CrNi17)
Stainless Steel 316	IS 1570 (part V) Gr. X04Cr17Ni12Mo2	ASTMA 276 type 316	1.4401(X5CrNiMo17122)
Stainless Steel 316L	IS 1570 (part V) Gr. X02Cr17Ni12Mo2	ASTMA 276 type316L	1.4404(X2CrNiMo1810)
Cast Duplex Steel			
Duplex Steel 1A		ASTMA 890 Gr. CD4MCu	25Cr-5Ni-Mo-Cu
Duplex Steel 2A		ASTMA 890 Gr. CE8MN	24Cr-10Ni-Mo-N
Duplex Steel 3A		ASTMA 890 Gr. CD6MN	25Cr-5Ni-Mo-N
Super Duplex steel 4A		ASTMA 890 Gr. CD3MN	25Cr-7Ni-Mo-N
Super Duplex steel 5A		ASTMA 890 Gr. CE3MN	24Cr-10Ni-Mo-N
Non Ferrous Materials			
Bronze	IS 318 Gr. LTB2 (CuSn5Zn5Pb5C)	ASTMB 584 - C90500	DIN 1705 Rg 5
Phosphor Bronze	IS 28 Gr. 1 (CuSn11PC)		
Zinc Free Bornze	IS 28 Gr. 1 (CuSn10C)		

FAMILY CURVES

Family Curve of KPD Process Pump at 1450 rpm- 50Hz

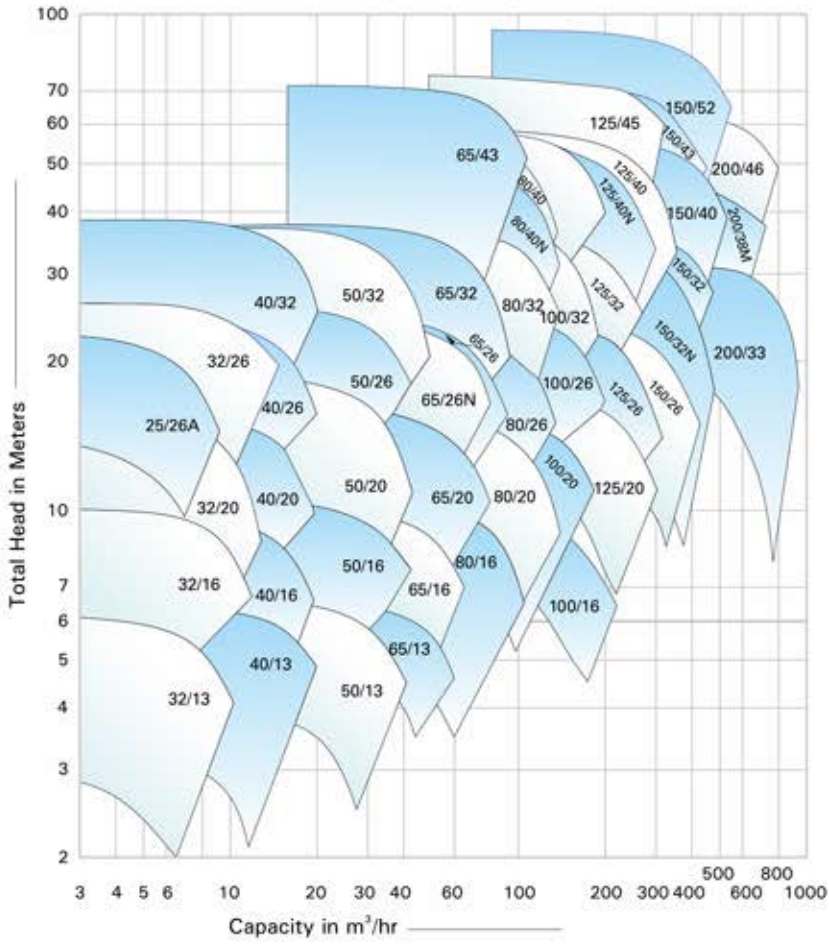

Family Curve of KPD Process Pump at 2900 rpm- 50Hz

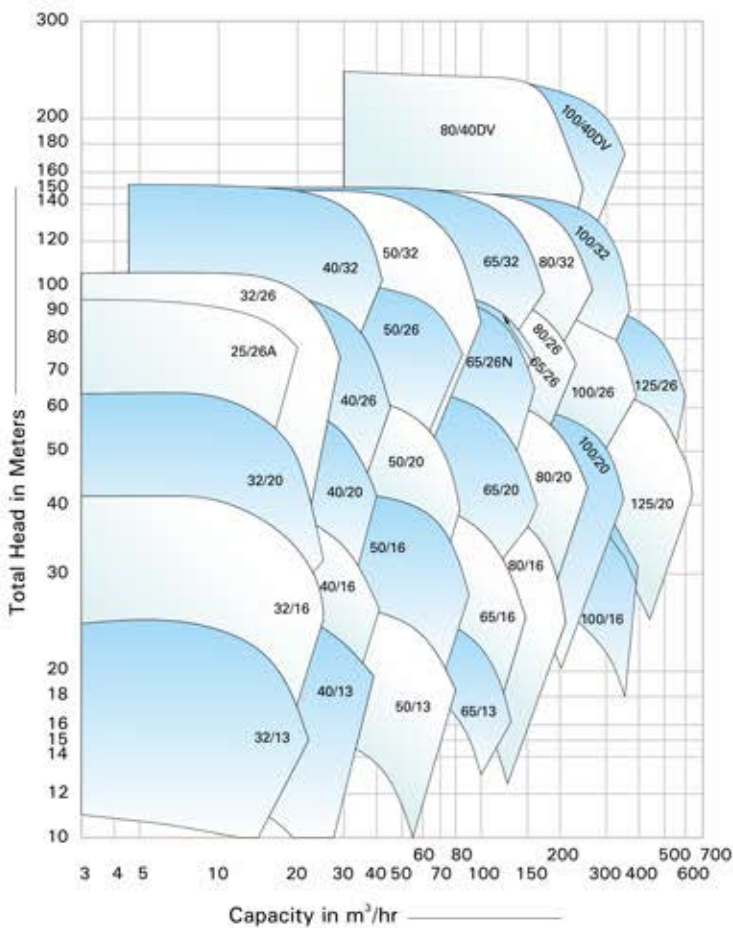

FAMILY CURVES

Family Curve of KPD-QF Process Pump at 1450 rpm 50 Hz

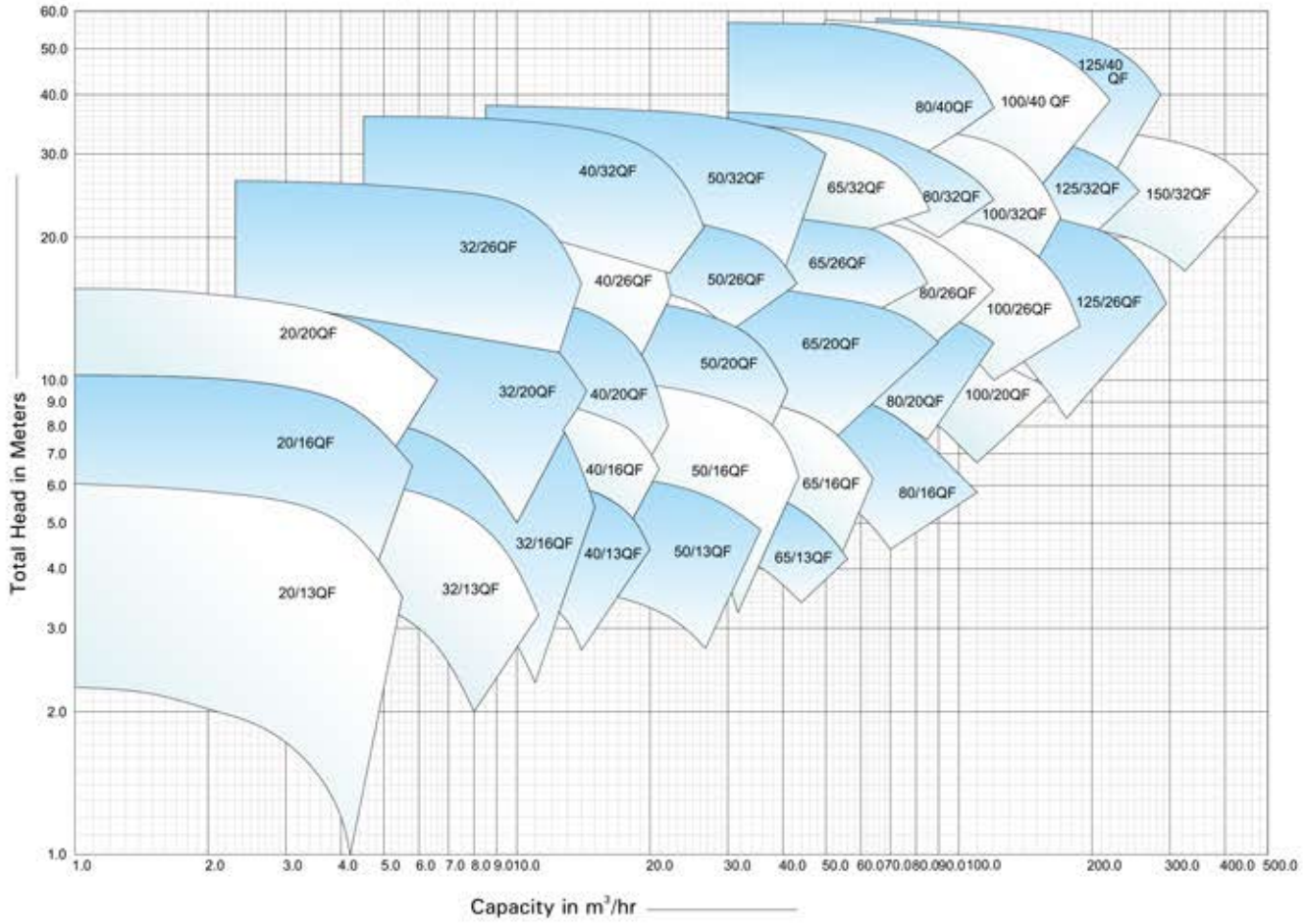

Family Curve of KPD-QF Process Pump at 2900 rpm 50 Hz

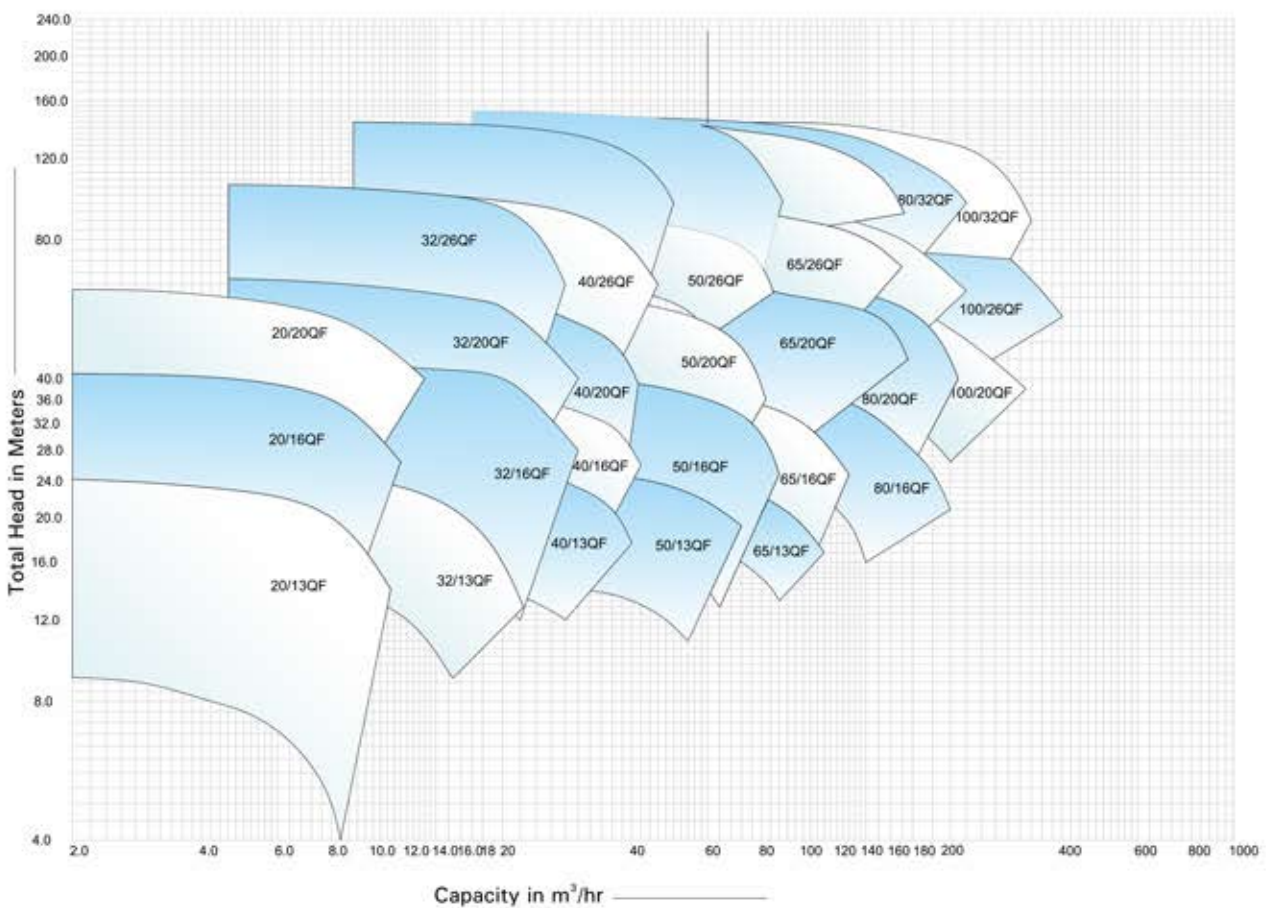

FAMILY CURVES

Family Curve of KPDT Pump at 1450 rpm

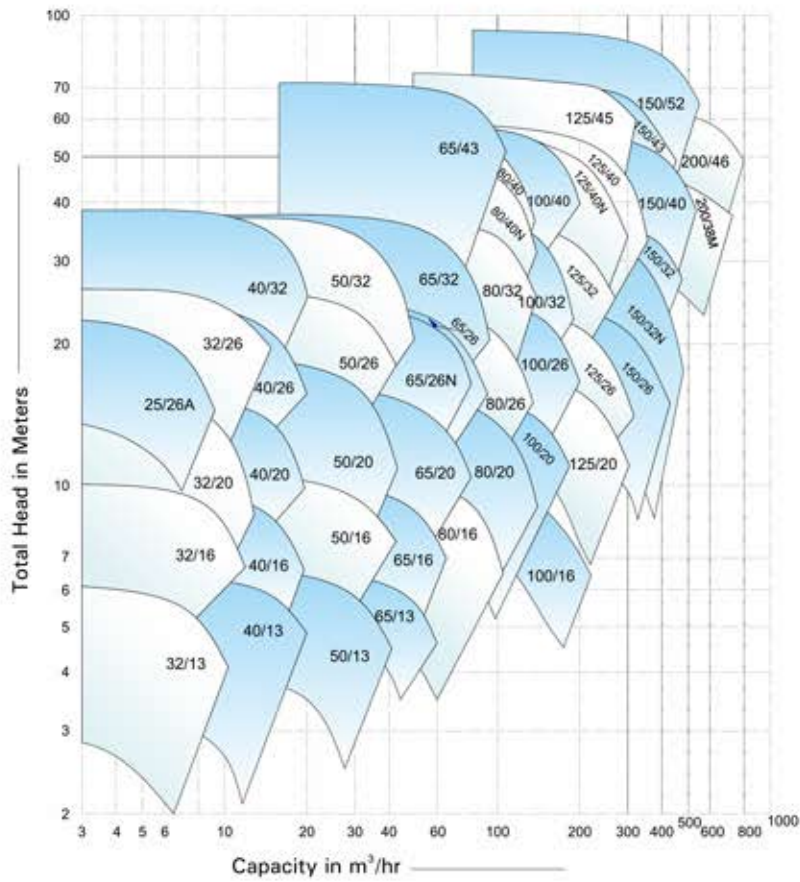

Family Curve of KPDT Pump at 2900 rpm

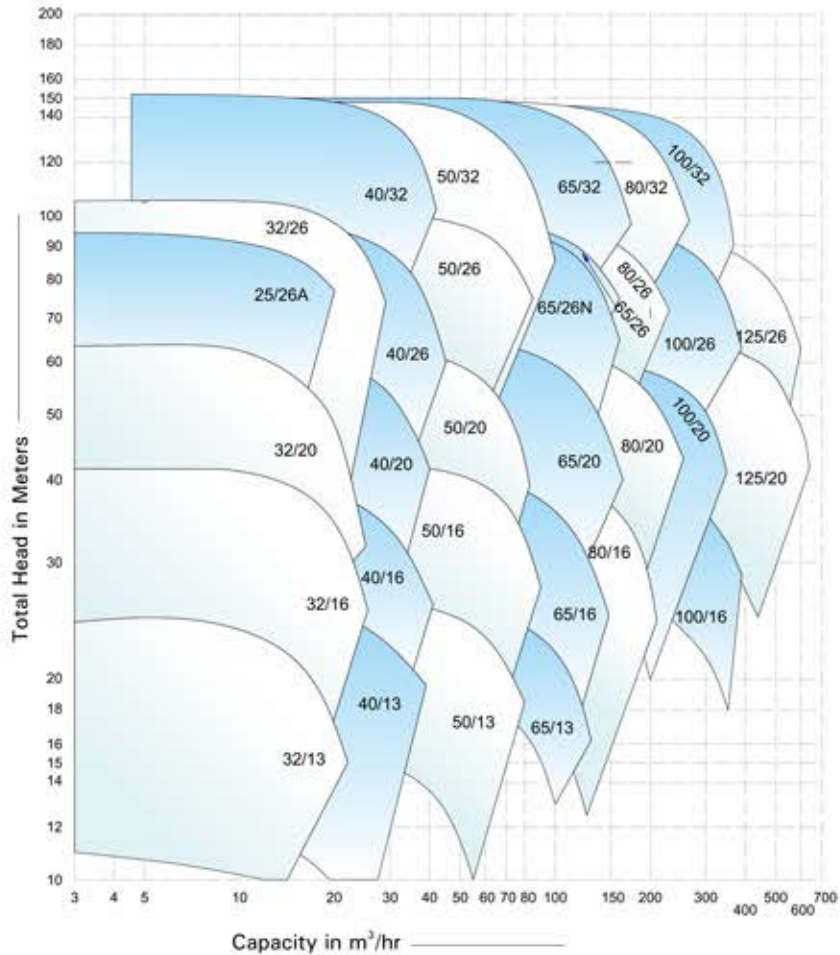

ABOUT KBL

Kirloskar Brothers Limited (KBL) is a world class pump manufacturing company with expertise in engineering and manufacture of systems for fluid management. Established in 1888 and incorporated in 1920, KBL is the flagship company of the \$ 2.1 billion Kirloskar Group. KBL, a market leader, provides complete fluid management solutions for large infrastructure projects in the areas of water supply, power plants, irrigation, oil & gas and marine & defence. We engineer and manufacture industrial, agriculture and domestic pumps, valves and hydro turbines.

In 2003, KBL acquired SPP Pumps, United Kingdom and established SPP INC, Atlanta, USA, as a wholly owned subsidiary of SPP, UK to expand its international presence. In 2007, Kirloskar Brothers International B.V., The Netherlands and Kirloskar Brothers (Thailand) Ltd., a wholly owned subsidiary in Thailand, were incorporated. In 2008, KBL incorporated Kirloskar Brothers Europe B.V. (Kirloskar Pompen B.V. since June 2014), a joint venture between Kirloskar International B.V. and Industrial Pump Group, The Netherlands. In 2010, KBL further consolidated its global position by acquiring Braybar Pumps, South Africa. SPP MENA was established in Egypt in 2012. In 2014, KBL acquired SyncroFlo Inc., the largest independent fabricator of commercial and municipal domestic water booster pumps.

To further strengthen its global position, in 2015, Kirloskar Pompen B.V. acquired Rodelta Pumps International, The Netherlands.

KBL has joint venture cooperation with Ebara, Japan since 1988 for the manufacture of API 610 standard pumps. Kirloskar Corrocoat Private Limited is a joint venture cooperation with Corrocoat, UK since 2006. KBL acquired The Kolhapur Steel Limited in 2007 and Hematic Motors in 2010.

KBL has eight manufacturing facilities in India at Kirloskarvadi, Dewas, Kondhapuri, Shirwal, Sanand, Kaniyur, Kolhapur and Karad. In addition, KBL has global manufacturing and packaging facilities in Egypt, South Africa, Thailand, The Netherlands, United Arab Emirates, United Kingdom and United States of America. KBL has 12,700 channel partners in India and 80 overseas and is supported by best-in-class network of Authorised Centres and Authorised Refurbishment Centres across the country.

All the manufacturing facilities at KBL are certified for ISO 9001, ISO 14001, ISO 50001, BS OHSAS 18001 and SA8000. In addition, the Kirloskarvadi plant is also certified for N & NPT Stamp. KBL's corporate office in Pune is certified for ISO 9001 & Sa8000.

The factories deploy Total Quality Management tools using European Foundation for Quality Management (EFQM) model. The Kirloskarvadi plant of KBL is a state-of-the-art integrated manufacturing facility having Asia's largest hydraulic research centre with testing facility upto 5000 kW and 50,000 m³/hr.

KBL is the ninth pump manufacturing company in the world to be accredited with the N and NPT certification by American Society of Mechanical Engineers (ASME).

Pumps | Valves | Hydro Turbines | Turnkey Projects

Water Resource Management | Irrigation | Power | Industry | Oil & Gas | Marine & Defence | Building & Construction |
Distribution (Small Pumps) | Valves | Customer Service & Spares

KIRLOSKAR BROTHERS LIMITED A Kirloskar Group Company

Registered Office: Udyog Bhavan, Tilak Road , Pune 411002. Tel: +91(20)24440770
Global Headquarters: "Yamuna", Survey No. 98/(3.7), Baner, Pune 411045. Tel: +91(20)27214444
Email: marketing@kbl.co.in, Website: www.kirloskarpumps.com, CIN No.: L29113PN1920PLC000670

